

MV "PATRIA" FACT SHEET

CALL SIGN: V2AE6 - IMO NO. 9159921

T/C OWNERS: K/S COMBI LIFT - 4220 KORSOER - DENMARK

PORT OF REGISTRY: ST. JOHNS

FLAG: ANTIGUA



MAIN PARTICULARS :

CLASS:

GL + 100 A5 E RO-RO VESSEL – STRENGTHENED FOR HEAVY CARGO - EQUIPPED FOR CARRIAGE OF CONTAINERS/HEAVY CARGO/DANGEROUS GOODS

BUILDERS:

TGS PENDIK SHIPYARD, TURKEY – 1999

REGISTER TONNAGE:

TYPE	INTERNATIONAL
GROSS	5825
NET	2545

DIMENSIONS:

LENGTH OVER ALL	100,90 M
LENGTH BETWEEN PP	94,60 M
BREADTH MOULDED	18,70 M
DESIGN DRAFT MOULDED	6,90 M
DEPTH TO MAINDECK MOULDED	10,15 M

DEAD WEIGHT CAPACITIES:

DEAD WEIGHT A.T.

5.300 MTS

CONTAINER CAPACITIES:

TOTAL CAPACITY 20' x 8' x 8'6"	544
HEREOF: IN CARGO HOLD	223
ON DECK	321
CAPACITY WITH AVERAGE 14 TS REEFER CONTAINERS	320
	40

STACKLOAD:

TANKTOP		
96 TS EACH 20'	120 TS EACH 40'	
TWEENDECK	40 TS EACH 20'	60 TS EACH 40'
MAINDECK	50 TS EACH 20'	80 TS EACH 40'

CARGO HOLDS:

BOXED - STEEL FLOORING 20 AIR CHANGES PER HOUR IN PORT
10 AIR CHANGES PER HOUR AT SEA

HATCHES:

1 HATCH WEATHERDECK	70,3 M X 15,2 M
1 HATCH TWEENDECK	51,3 M X 15,2 M

CUBIC CAPACITIES IN HOLDS:

WITH TWEEN-DECK HATCH COVERS 10.600 CBM

CRANES:

2 ELECTRO HYDRAULIC CRANES PORT SIDE 150 TS / 13 M & 52 TS / 26 M COMBINABLE UP TO 300 TS

DECK STRENGTH:

TANKTOP - STEEL	10,0 TS PER M2
TWEEN DECK - STEEL PONTOONS	3,0 TS PER M2
MAIN DECK - STEEL PONTOONS	2,3 TS PER M2

SPEED AND CONSUMPTION:

15,0 KNOTS ON ABT 19 TS IFO 380
NO GASOIL AT SEA

TANK CAPACITIES:

FUELOIL	ABT. 670 TS
FRESH WATER	150120 TS
BALLAST WATER	2100 TS

ENGINES:

MAIN ENGINE 1 MAN B&W 9L 32/40
AUX. ENGINES: 2 MAN B&W 4- STROKE DIESEL ENGINES

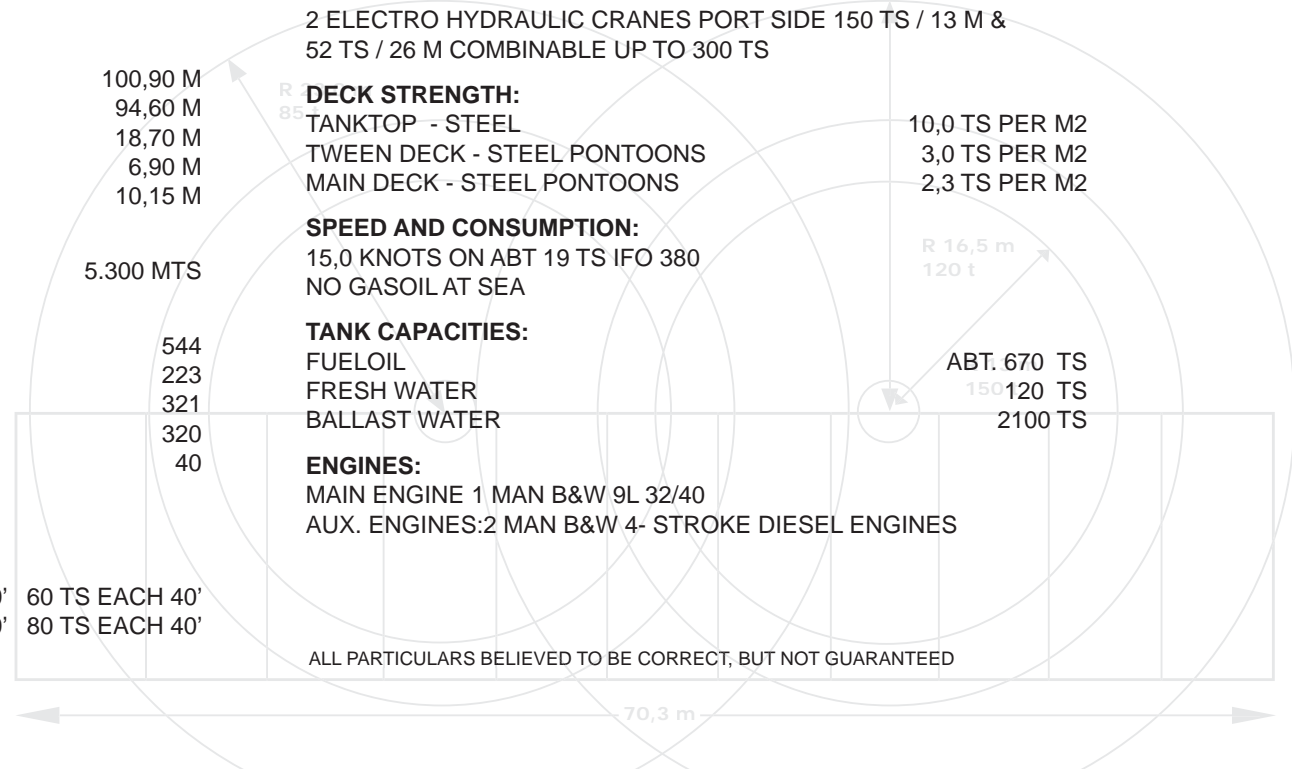

ALL PARTICULARS BELIEVED TO BE CORRECT, BUT NOT GUARANTEED

LOWER HOLD

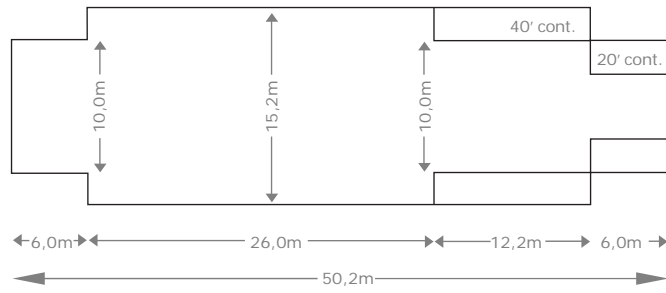

HOLD 1

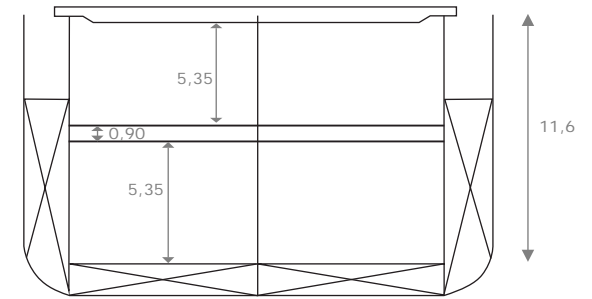

TWEEN DECK

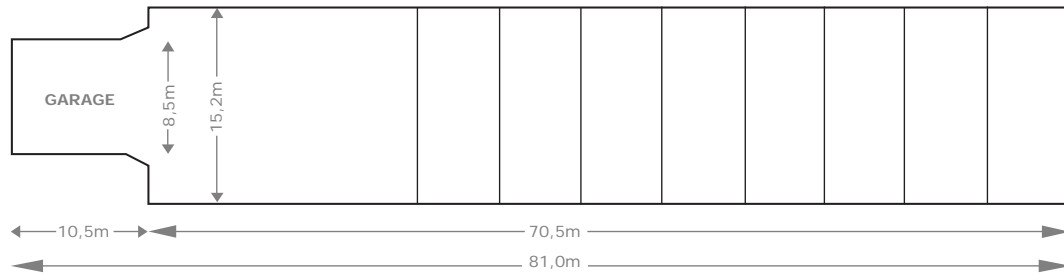

WEATHER DECK

