

FACT SHEET

MV "PANAGIA" - MV "PANTANAL" - MV "PANGANI"

MV PANAGIA: CALL SIGN: V20Q5 - IMO NO: 9305295
 MV PANTANAL: CALL SIGN: V2PN8 - IMO NO: 9316579
 MV PANGANI: CALL SIGN: ZDHC4 - IMO NO: 9318943

T/C OWNERS: K/S COMBI LIFT - 4220 KORSOER - DENMARK
 PORT OF REGISTRY: ST. JOHNS
 FLAG: ANTIGUA



MAIN PARTICULARS :

CLASS:

GL + 100 A5EG EQUIPPED FOR CARRIAGE OF CONTAINERS AND DANGEROUS CARGO IMO 1.1. MC AUT STRENGTHENED FOR HEAVY CARGO.

BUILDERS:

XINGANG SHIPYARD, TIANJIN YARD NO 328/337-2 – 2004

REGISTER TONNAGE:

TYPE	INTERNATIONAL
GROSS	7002
NET	3375

DIMENSIONS:

LENGTH OVER ALL	119,80 M
LENGTH BETWEEN PP	113,50 M
BREADTH MOULDED	20,20 M
DRAFT FULLY LOADED SUMMER	7,59 M

DEAD WEIGHT CAPACITIES:

DEAD WEIGHT A.T.	7821 MTS
DEAD WEIGHT C.C.	ABT. 7200 MTS

CONTAINER CAPACITIES:

TOTAL CAPACITY 20' x 8' x 8'6"	599
HEREOF: IN CARGO HOLD	238
ON DECK	361
CAPACITY WITH AVERAGE 14 TS	377
REEFER CONTAINERS	36

STACKLOAD:

TANKTOP	100 TS EACH 20' 120 TS EACH 40'
DECK	60 TS EACH 20' 80 TS EACH 40'

CARGO HOLD:

FITTED FOR DANGEROUS CARGO SOLAS -II-2, REG 54 HOLDS FITTED WITH SMOKE DETECTORS, CO2 SYSTEM, SPRINKLER

HATCHES:

HATCH NO. 1	12,63 X 15,15 + 6,22 X 9,94 M
HATCH NO. 2	52,00 X 16,10 X 10,80 M

BOXSHAPED

CUBIC CAPACITIES IN HOLDS:

WITH TWEEN-DECK HATCH COVERS	11069 CBM
------------------------------	-----------

CRANES:

2 ELECTRO HYDRAULIC CRANES PORT SIDE 250 TS / 12 M & 100 TS / 26 M COMBINABLE UP TO 500 TS

DECK STRENGTH:

TANKTOP - STEEL 16,0 TS PER M2
 TWEENDECK – HOLD NO. 1 2,5 TS PER M2
 TWEENDECK – HOLD NO. 2 3,0 TS PER M2
 HATCH COVER 2,5 TS PER M

SPEED AND CONSUMPTION:

15,0 KNOTS ON ABT 19 TS IFO 380
 NO GASOIL AT SEA

TANK CAPACITIES:

FUELOIL	ABT. 751,8 TS
MGO	ABT. 89,3 TS
FRESH WATER	ABT. 140 TS
BALLAST WATER	ABT. 4048,8 TS

ALL PARTICULARS BELIEVED TO BE CORRECT, BUT NOT GUARANTEED

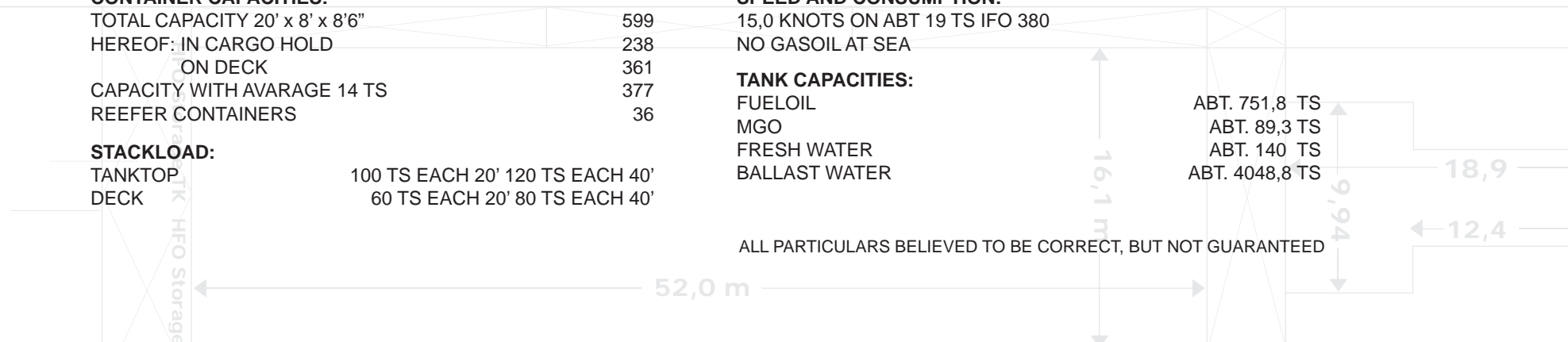

TANK TOP

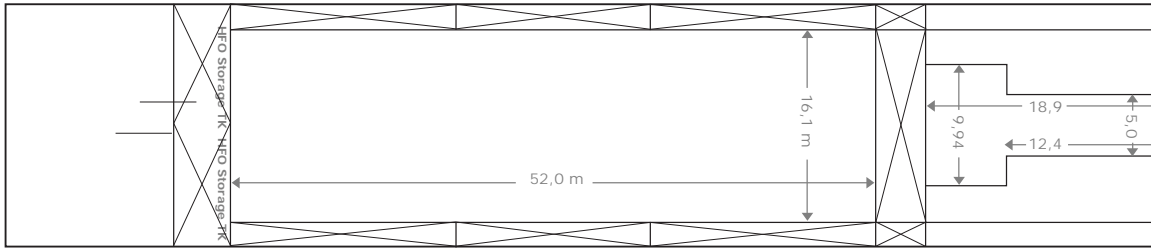

HOLD 1

HOLD 2

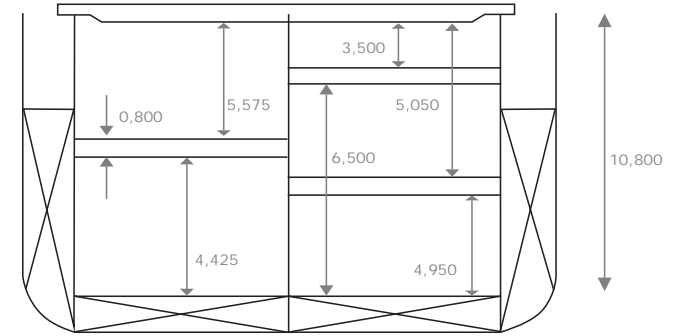

TWEEN DECK

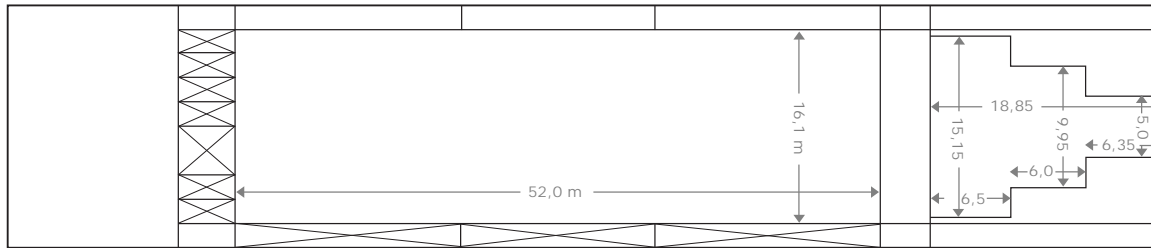

WEATHER DECK

