

M.V. "PALMERTON" - M.V. "PALABORA" + 2 NEWBUILDINGS

MV "PALMERTON": CALL SIGN: V2EM7 - IMO NO: 9501863
 MV "PALABORA": CALL SIGN: V2ES2 - IMO NO. 9501875
 2 NEWBUILDINGS: DELIVERY: APRIL 2010 / JULY 2010

T/C OWNERS: K/S COMBILIFT - 4220 KORSOER - DENMARK
 PORT OF REGISTRY: ST. JOHNS
 FLAG: ANTIGUA



MAIN PARTICULARS :

CLASS:

GL +100 A5 E3 MULTI-PURPOSE DRY CARGO SHIP
 EQUIPPED FOR CARRIAGE OF CONTAINERS
 AND DANGEROUS GOODS
 STRENGTHENED FOR HEAVY CARGO
 NAV-O, BWM, ENVIROMENTAL PASSPORT
 +MC AUT E3, IW

BUILDERS:

PALMERTON: KOUAN SHIPYARD - NOVEMBER 2009
 PALABORA: KOUAN SHIPYARD - JANUARY 2010
 2 NEWBUILDINGS: APRIL 2010 / JULY 2010
 OCTOBER 2010

REGISTER TONNAGE:

TYPE	INTERNATIONAL
GROSS	11.473
NET	3834

DIMENSIONS:

LENGTH OVER ALL	133,00 M
LENGTH BETWEEN PP	122,85 M
BREADTH MOULDED	23,00 M
DESIGN DRAFT LOADED SUMMER	7,80 M

DEAD WEIGHT CAPACITIES:

DEAD WEIGHT A.T.	10.128 MTS
------------------	------------

CARGO HOLD:

BOXED – STEEL FLOORING – TWEEN DECK HOISTABLE IN 3
 DIFFERENT HEIGHTS (SEE DRAWING)

CUBIC CAPACITIES IN HOLD:

TOTAL CUBIC CAPACITY	15.700 CBM
----------------------	------------

CRANES:

2 ELECTRIC HYDRAULIC CRANES PORT SIDE 450 TS / 17,5 M & 250
 TS / 30 M COMBINABLE UP TO 900 TS

DECK STRENGTH:

TANKTOP - STEEL	16,0 TS PER M2
TWEEN DECK - STEEL PONTOONS	4,5 TS PER M2
MAIN DECK - STEEL PONTOONS	2,5 TS PER M2

SPEED AND CONSUMPTION:

16,20 KTS

TANK CAPACITIES:

FUELOIL	1.244 M3
MDO	125 M3
FRESH WATER	180 M3
BALLAST WATER	7.800 M3

TANK TOP

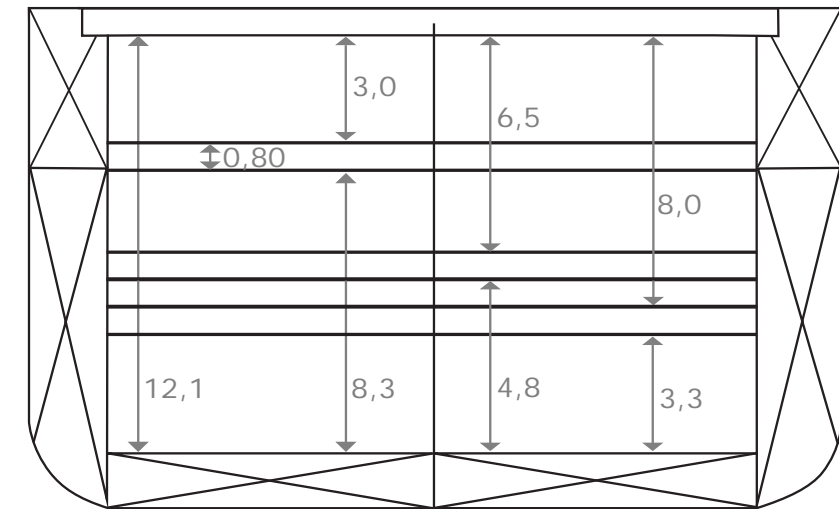
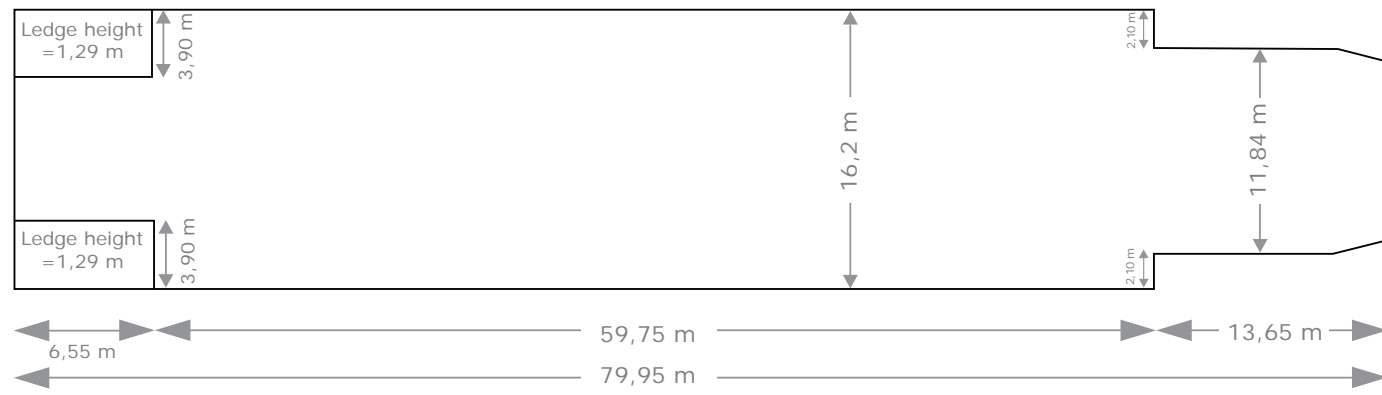

HATCH OPENING/TWEEN DECK

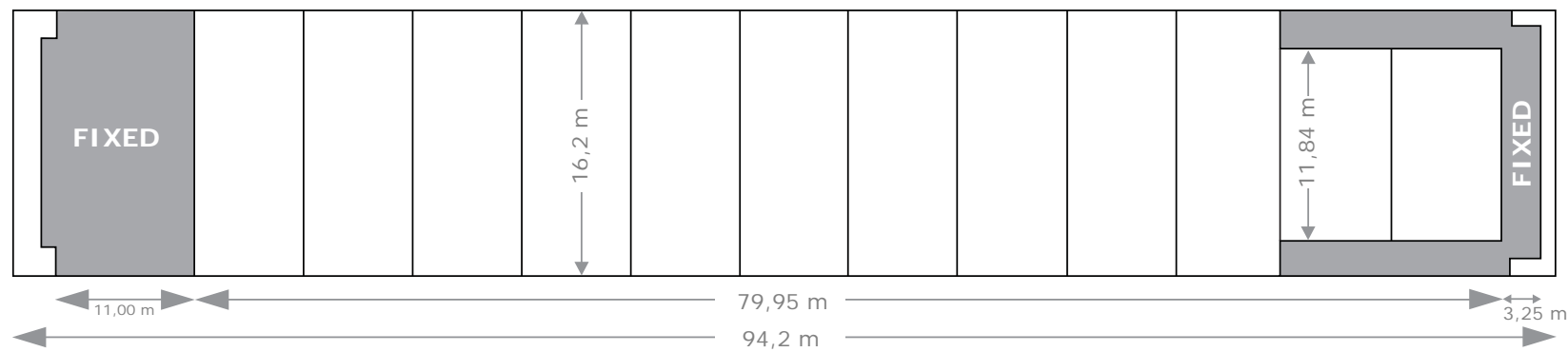

Hatch opening/tween deck highest position 94,2x16,2, Tween deck middle and lowest position 80x16,2.

WEATHER DECK

